

INSTRUCTION MANUAL

CUSTERS Foldy Mobile Scaffold



Max load capacity:	1500 lbs. 75lb/ft ² (2 persons plus equipment)
Max platform height:	configurations up to 18 ft.
Max working height:	configurations up to 24 ft.

February 2023

Contents

1. Introduction	3
2. Warranty and liability	5
3. Inspection of the delivery	5
4. Safety instructions	6
4.1 Inspection before assembly	6
4.2 Assembly	7
4.3 Lifting of parts	7
4.4 Outriggers	8
5. Assembling the scaffold	9
5.1 Platform height 3.3 ft. (safe working height 10 ft.)	9
5.2 Platform height 5.9 ft. (safe working height 13 ft.)	10
5.3 Platform height 11.51 ft. (safe working height 18 ft.)	12
6. Using the scaffold	14
7. Moving the scaffold	15
8. Anchoring	15
9. Disassembling the scaffold	15
10. Maintenance	16
11. Parts list	17
11.1 Platform height 3.3 ft. (safe working height of 10 ft.)	17
11.2 Platform height 5.9 ft. (safe working height of 13 ft.)	18
11.3 Platform height 11.5 ft. (safe working height of 18 ft.)	19

© Custers Hydraulica B.V., Venray - the Netherlands, February 2023

All rights reserved.

No part of this publication may be reproduced / copied or published by photography / printing / microfilm / video / CD-ROM / Internet or any other form, without prior permission in writing by Custers Hydraulica B.V. No rights can be derived from this publication.

1. Introduction

The CUSTERS Foldy scaffold is part of a wide range of aluminum scaffold-products manufactured by Custers Hydraulica BV in the Netherlands.

If assembled according to the instructions given in this manual, the CUSTERS Foldy scaffold meets the requirements of the EN1004 and complies with the standards of CAN/CSA S269.2-16, ANSI/SSFI Standard SC100-5/05 and OSHA 29CFR PART 1926.

The CUSTERS Foldy scaffold is available in the following versions:

- Platform heights: 3.3 ft., 5.9 ft., 11.5 ft.
- Working/reaching heights: 10 ft., 13 ft., 18 ft.

The maximum load of the scaffold is 1500 lbs. depending on the version. The maximum workload per platform is 75lb/ft² (Heavy duty). (See chapter 6 for more info).

 This manual instructs you step by step how to erect your scaffold in an easy and safe way.

FAILURE TO READ, UNDERSTAND AND FOLLOW THESE INSTRUCTIONS AND ALL SAFETY RULES COULD RESULT IN SERIOUS INJURY OR DEATH.



WARNING: METAL IS CONDUCTOR OR ELECTRICITY: ALWAYS CHECK FOR POWER LINES, OTHER LIVE WIRES OR CIRCUITS. DO NOT USE IF CONTACT IS POSSIBLE.



WARNING: Erecting scaffolding should only be performed by trained, competent and qualified professionals familiar with local, state, or provincial safety regulations. Always consult and adhere to guidelines set forth by governing bodies such as OSHA in the United States or CCOHS in Canada to ensure the safety of workers and the public.

The user is responsible for having this manual at the erecting / working site. The user is also responsible for having the manual in the site-supervisor's possession.

If you have any questions regarding this manual, please do not hesitate to contact your supplier or the manufacturer.

Manufacturer:

Custers Hydraulica B.V.
Smakterweg 33
5804 AE Venray, The Netherlands
Telephone: +31 (0) 478 553 000
E-mail: info@custers.nl
Website: www.custers.nl

Supplier:

2. Warranty and liability

CUSTERS warrants that the products and accessories will be free from defects in material and workmanship for a period of 12 months from the date of delivery. Please note that this warranty does not cover damage caused by improper maintenance, misuse, or modifications of any part of the products.

Please note that to process your claim, you will need to provide proof of purchase of the product, pictures, and a summary of the claim. Other information may be required.

For all defects reported to us within the warranty period our liability is limited to repairing or replacing any defective products based on our opinion and at no charge to the customer. If for discharge of our liability under the warranty we replace (parts of) products supplied by us, the products (or parts) replaced will become our property. All costs and expenses exceeding the liability specified above, including but not limited to transport charges, travel expenses and the cost of disassembly and reassembly, will be at the expense of the customer. If for the discharge of our liability under this warranty we carry out repairs to products supplied by us, the products concerned shall remain entirely at the risk of the customer.

Our responsibility is limited and excludes:

- a. If any defect is the result of abuse, misuse or inexpert use, or the result of other causes than unfitness of material or workmanship.
- b. If the cause of any defect cannot be conclusively proved.
- c. If our instruction for the use of the products and other specifically applicable warranty instructions have not been accurately and fully observed.

Our warranty will cease if during the warranty period the customer (or any person acting on the customer's instruction) has subjected the products supplied by us or our authorized suppliers to unauthorised modifications and/or repairs.

3. Inspection of the delivery

The customer must immediately inspect the tower scaffold, including all parts and any accessories upon delivery. Contact your supplier immediately if parts are damaged and/or the scaffold incomplete. **DO NOT USE THE SCAFFOLD IF THERE ARE ANY MISSING PARTS OR DAMAGE IS IDENTIFIED.**

4. Safety instructions

4.1 Inspection before assembly

Check that the workers (at least two), meet the requirements to erect, inspect, use or disassemble scaffolding in accordance with provisions and definitions set out in OSHA (Occupational Safety and Health Administration) in the United States or in Canada, generally, the Canadian Centre for Occupational Health and Safety (CCOHS). In both United States and Canadian regulations, a “competent person” is generally someone capable of identifying existing and predictable workplace hazards and has the authority or authorization to correct or eliminate them. These individuals must also be qualified through knowledge, training, and experience to perform the work safely and is familiar with the applicable safety regulations.

Make sure that:

- The surface is flat and hard and free of hazards.
- The area is free from obstacles, both on the ground and above.
- The wind-conditions allow working with the scaffold (see chapter 6).
- All parts and ropes required for pulling up material, are present at the site.
- Damaged, wrong or non-original parts are never used.

4.2 Assembly

The scaffold assembly as described in the assembly instructions, must be done by at least two people (applicable to platform height 11.5

Always use (temporarily mounted) guardrails during the assembly.

The scaffold must be assembled on a flat surface.

The wheels must always be locked, except during moving it into place.

The platforms must be secured by sliding the wind-securing pin under the frame rung.

The frames must be secured with frame securing clips.

The horizontal and backside frames must be mounted on the frames with the open side of the claw pointing to the scaffold outside.

The working level (platform height 5.9/11.5) must always be equipped with a trapdoor platform; the working level (platform height 11.5) must be equipped with principal guardrails, intermediate guardrails and toe boards all-around.

4.3 Lifting of parts

Lifting or pulling up parts should be done by handing the parts from one platform to the other.

Parts can also be pulled up by using a strong rope. Use a proper knot, noose or hook to connect the parts.

Lifting or lowering parts, materials and tools with a rope should be done on the inner side of the scaffold.

It is not allowed attaching lifting equipment onto a free-standing scaffold.

Picture 1: Lifting

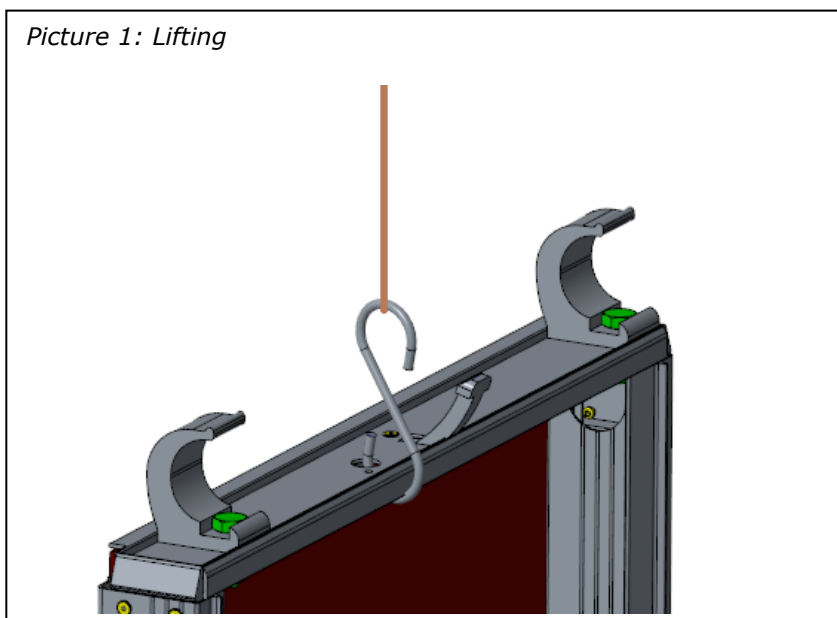

4.4 Outriggers

The outriggers, if chosen and or if necessary, must always be mounted as soon as the lower part of the scaffold has been built.

The instructions in the pictures below (outriggers 45 degrees rotated) are to be strictly followed!

Disregarding these instructions imply that you should use additional ballast weight (contact the distributor / supplier).

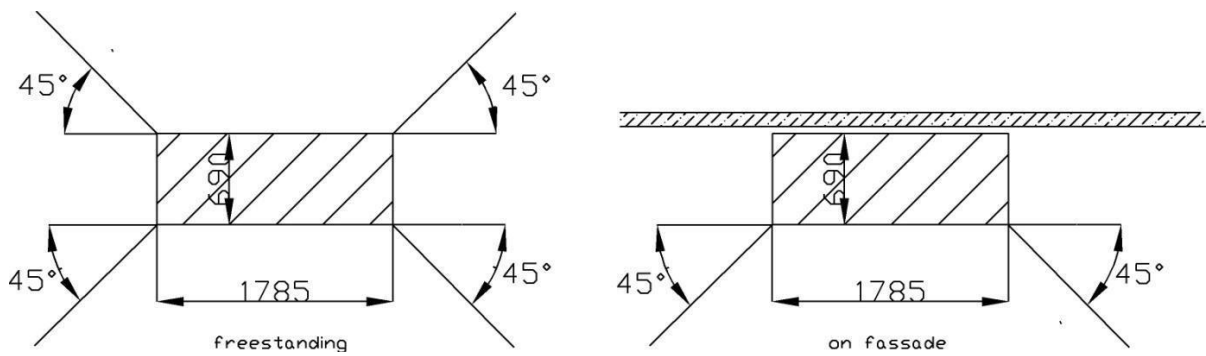

5. Assembling the scaffold

5.1 Platform height 3.3 ft. (safe working height 10 ft.)



1: if necessary: mount 4 x wheel
(Insert eccentric of wheel in tube, firmly
turn on bolt with #10 Hex Key (not
provided))

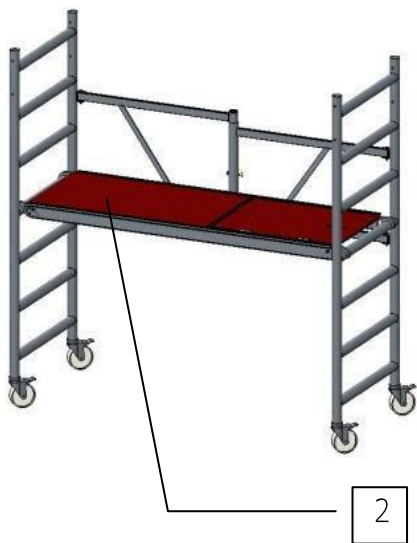

2: place trapdoor platform (or: platform without
trapdoor); slide the two wind securing
pins under each rung.

5.2 Platform height 5.9 ft. (safe working height 13 ft.)

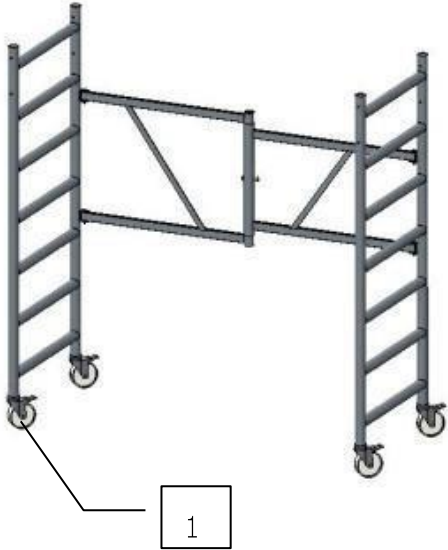

1: if necessary: mount 4 x wheel (insert eccentric of wheel in tube, firmly turn on bolt, use #10 Hex Key if so equipped (not included)).



2: Insert the end guardrails; secure the guardrail with securing clips at each connection point.



- 3: place trapdoor platform; slide both wind securing pins under the rung
- 4: place the 4 horizontal guardrails with Red Tab block (open side of claws pointed to the outside).



5.3 Platform height 11.51 ft. (safe working height 18 ft.)

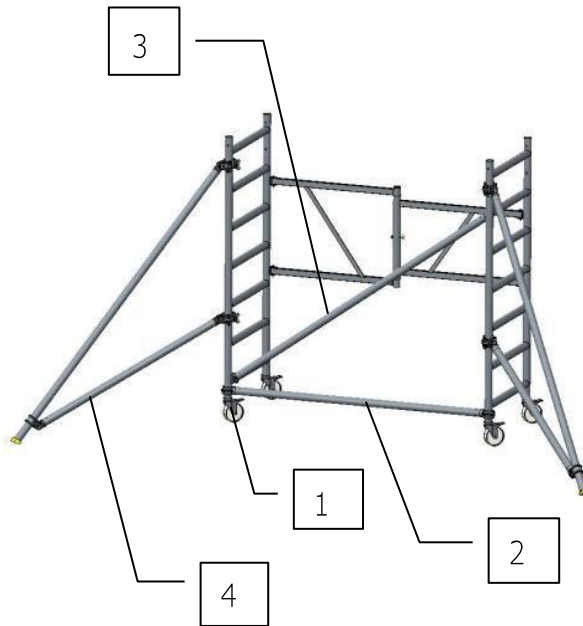

- 1: if necessary: mount 4 x wheel
(Insert eccentric of wheel in tube, firmly turn on bolt with #10 Hex Key (not included)).
- 2: place the horizontal guardrail (open side of claws pointed to the outside)
- 3: place the diagonal blue tab claws on rung 1 & 6 or 1 & 4 (depending on diagonal included).
- 4: assemble the chosen or equipped outriggers.
 - place the upper coupling on the stand below the rung
 - put base foot on the ground
 - loosely attach the bottom coupling to the stand and push the coupling up over the stand until the outrigger is a little bit under pressure
 - firmly tighten both couplings

NOTE: when using the scaffold freestanding use four (4) outriggers

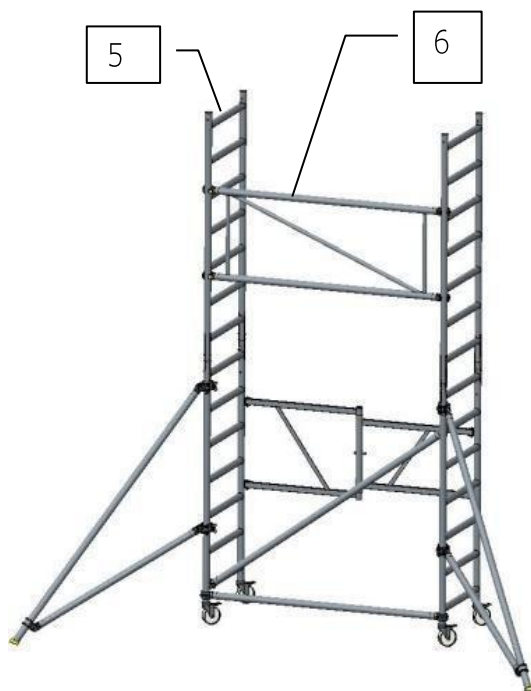

- 5: place the 7 rung mounting frames; secure the frames with securing clips
- 6: place the backside frame (if equipped) between the mounting frames (open side of claws pointed to the outside)



- 7: place trapdoor platform; slide both wind securing pins under the rung
- 8: place the end guardrails; secure the guardrail with securing clips

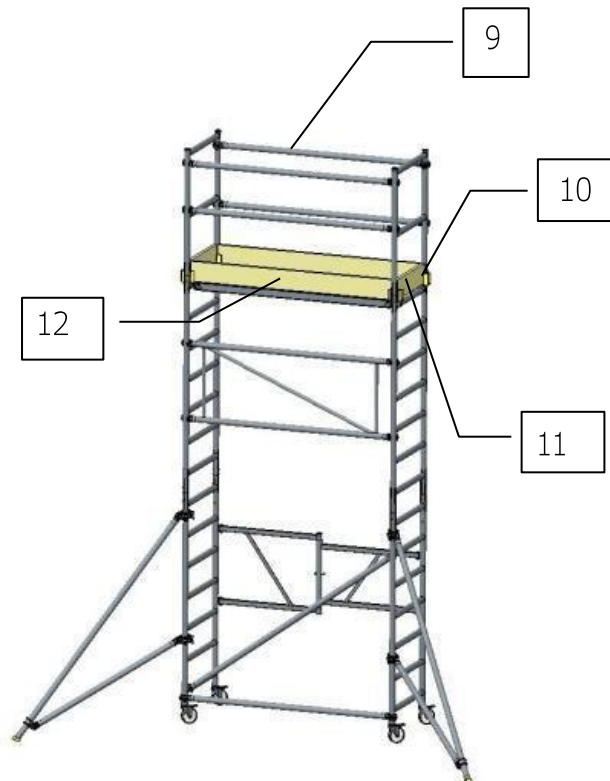

- 9: place the 4 horizontal braces with Red Tab Claws (open side of claws pointed to the outside)
- 10: place the 4 toe board holders
- 11: place both toe boards (on the short side)
- 12: place both toe boards (on the long side)

6. Using the scaffold

Prior to every use you must check whether:

- The base of the scaffold is correct.
- The total composition / construction is correct and complete.
- There is no change in conditions, which affect the safe use of the scaffold.

The scaffold is built to provide a safe working place at heights.

It is not allowed to use the scaffold as a stairway-tower for other construction or applications. It is also prohibited from using it as suspended scaffold or using it for stepping over to other construction sites. It is forbidden to use bridges between mutual scaffolds or between a scaffold and a building.

The maximum workload per platform is 75lb/ft² (Heavy duty). Only one working level can be loaded, the load may not exceed 1500 lbs.

You are not allowed to jump on the platforms; the trapdoor must always be closed, except when you are climbing up or down.

The maximum platform height is dependent of the version being used

-: 3.3ft, 5.9ft, 11.5ft.

You may only climb from the inside of the scaffold (onto frames)

Do not put boxes, ladders, stools, buckets or other equipment on the platform in order to gain height. It is forbidden to work on the scaffold if the wind force is stronger than 6 Beaufort (big leaves move, umbrellas bend, wind speed is 36.1-45.9 ft/s = ± 27.96mph).

If a wind force higher than 6 Beaufort is predicted, the scaffold must be disassembled, anchored or transported to a wind free area. This should also be done if the scaffold is not in use.

Please be careful with openings between buildings, edges and spots of buildings, extra wind forces could be possible.

The maximum allowed horizontal force is 66.1 lbs., so be aware of this when you exercise horizontal forces (e.g., drilling), which could endanger the stability of the scaffold. It is not allowed to step onto horizontals, diagonals and guardrails.

It is not allowed to attach wind-catching materials such as advertising boards or canvasses onto free-standing scaffolds.

Do not expose the scaffold to aggressive liquids or gases.

It is not allowed to attach lifting equipment onto a mobile scaffold.

7. Moving the scaffold

The scaffold may only be moved lengthways by hand from the ground. During this move you may not exceed the normal walking speed and no persons or materials are allowed on the scaffold during this move. Be aware of any obstacles that could be on/above the ground when you move the scaffold.

If the wind is stronger than 4 Beaufort it is forbidden to move the scaffold (dust, sand and paper blow up, little leaves are torn off, wind speed is 13.1-19.7 ft/s = ± 11.18mph). You should be very careful when the scaffold is moved over bad surfaces (inclined planes, insufficient load-carrying capacity, holes, etc.); the wheels should be free or braked, depending on the situation.

If you move the scaffold, the supporting points of the outriggers should only be a few inches above the ground. After moving, put the supporting points on the ground again.

8. Anchoring

Anchors must be used when the scaffold gets too unstable, e.g. by strong wind. The anchors must be solid and must be attached to both frame-stands by couplings. Anchor only on durable spots onto a construction or building.

At about 9.8 feet height 2 anchors must be used (so: one per frame when required).

9. Disassembling the scaffold

Disassembly is done in reverse order.

Lowering parts should be done by handing the parts from one platform to the other.

Disassemble the scaffold from the top to the base. Never throw parts to avoid worker injury, damage or injury or death to passersby.

10. Maintenance

All parts, particularly the pivoting parts and welds, must be inspected regularly, but at least once per year, looking for wear and damage. Lost or damaged parts must be replaced. Aluminum scaffolding parts are not allowed to be used in the following cases:

- When round tubes have one or more dull dents with a depth of more than 0.12 in.
- When round tubes have one or more dents directly next to a welding junction, despite the depth or shape of the dent.
- When square or rectangular tubes have one or more dull dents with a depth of more than 0.079 inch.
- When round or square tubes have one or more sharp dents or cracks, regardless length, depth or location of these dent(s)/crack.

Pivoting parts, for example wheels and jack plates, must be clean and run smoothly. Repair of scaffold material may only be done in consultation with the manufacturer or their representative.

11. Parts list

11.1 Platform height 3.3 ft. (safe working height of 10 ft.)

The following table lists the parts needed to properly and safely assemble a Custers Foldy scaffold with a platform height of 3.3 ft. **Make sure that all necessary parts are present, or do not use it!**

Number	Description	Part Number	# of parts	weight (lbs.)
1	Folding frame	771.010	1 (remark 1)	49.4
2	Trapdoor platform	316.015	1	27.6
	Frame Securing Clip	410.162 or 410.163	1	0.13

Remark 1: On uneven surfaces, use swivel locking Casters or Jack Plates with adjustable spindles (510.010, 510.065 or 520.010)

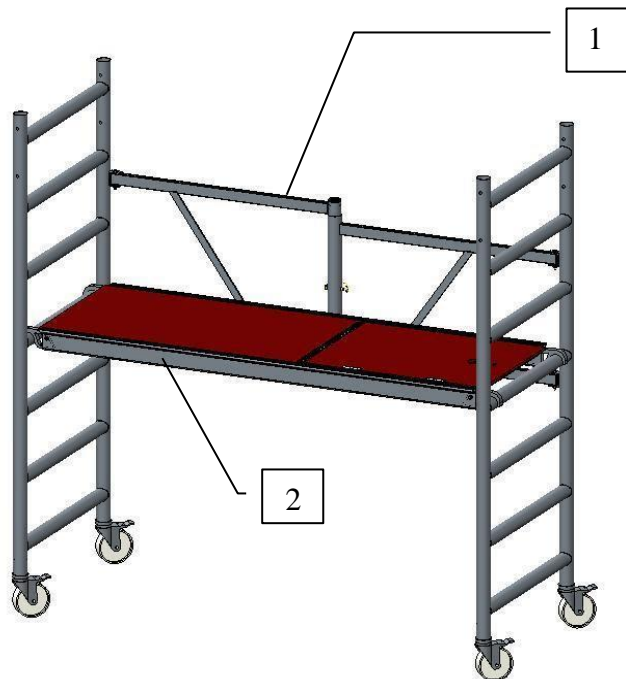

11.2 Platform height 5.9 ft. (safe working height of 13 ft.)

The following table lists the parts needed to properly and safely assemble a Custers Foldy scaffold with a platform height of 5.9 ft. **Make sure that all necessary parts are present, or do not use it!**

Number	Description	Part Number	# of parts	weight (lbs.)
1	folding frame (see remark 1)	771.010	1 (Remark 1)	49.4
2	trapdoor platform	316.015	1	27.6
3	Horizontal guardrail	200.058	2 or 4 (Remark 2)	4.4
4	end guardrail	720.001	2	7.94
5	securing clip	410.162 / 410.163	5	0.13

Remark 1: On uneven surfaces, use swivel locking Casters or Jack Plates with adjustable spindles (510.010, 510.065 or 520.010)

Remark 2: Only 2 horizontal guardrails are required if using the scaffold against a wall in accordance with provincial or state regulations (it's the users responsibilities to check). If using freestanding, 4 guardrails are mandatory.

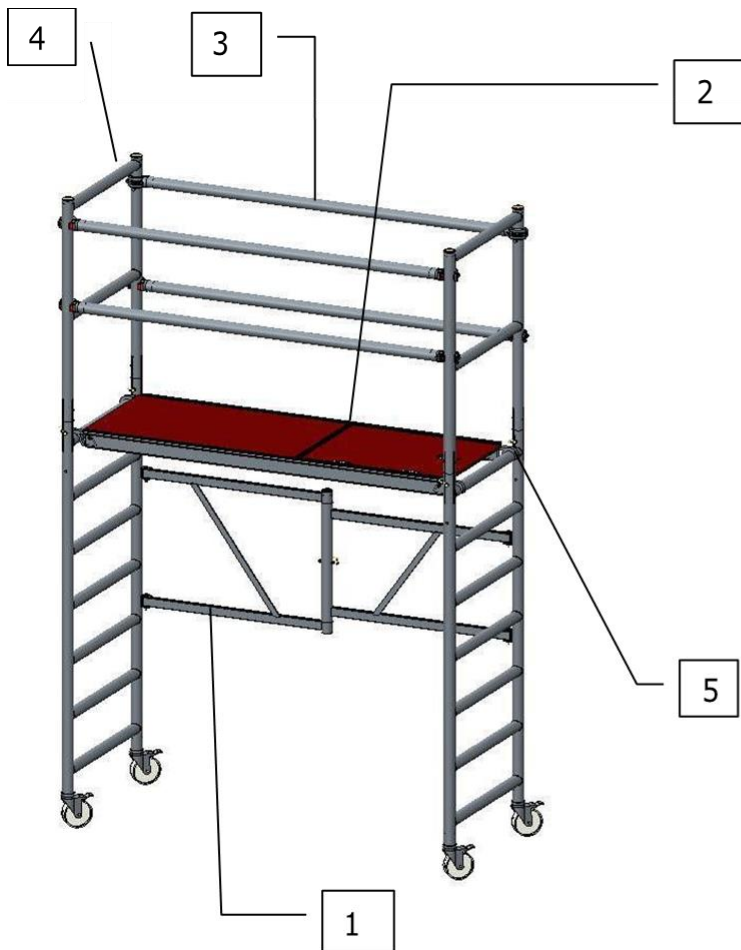

11.3 Platform height 11.5 ft. (safe working height of 18 ft.)

The following table lists the parts needed to properly and safely assemble a Custers Foldy scaffold with a platform height of 11.5 ft. Make sure that all necessary parts are present.

Number	Description	Part Number	# of parts	weight (lbs.)
1	backside frame	720.055	1	12.3
2	folding frame (see remark 1)	771.010	1	49.4
3	mounting frame	720.048	2	17.0
4	diagonal	200.057	1	5.5
5	trapdoor platform	316.015	2	27.6
6	horizontal	200.058	7	4.4
7	end guardrail	720.001	2	7.9
8	Toe board-holder	800.089	4	0.44
9	Toe board	200.086	2	5.5
10	Toe board	200.092	2	2.6
11	outrigger (see remark 2)	410.100 / 430.200	2 or 4	14.3
12	securing clip	410.163	9	0.13

Remark 1: on uneven surfaces, use swivel locking Casters or Jack Plates with adjustable spindles (510.010, 510.050, 510.065 or 520.010)

Remark 2: when using the scaffold freestanding (working overhead) ALWAYS use 4 outriggers (410.100 or 430.200)

Remark 3: as an alternative to backside frames (2 diagonal braces 200.057)

